

HOSEBED CAPACITIES

① 1000' OF 5.00" D.J. POLYESTER HOSE

② 1000' OF 3.00" D.J. POLYESTER HOSE

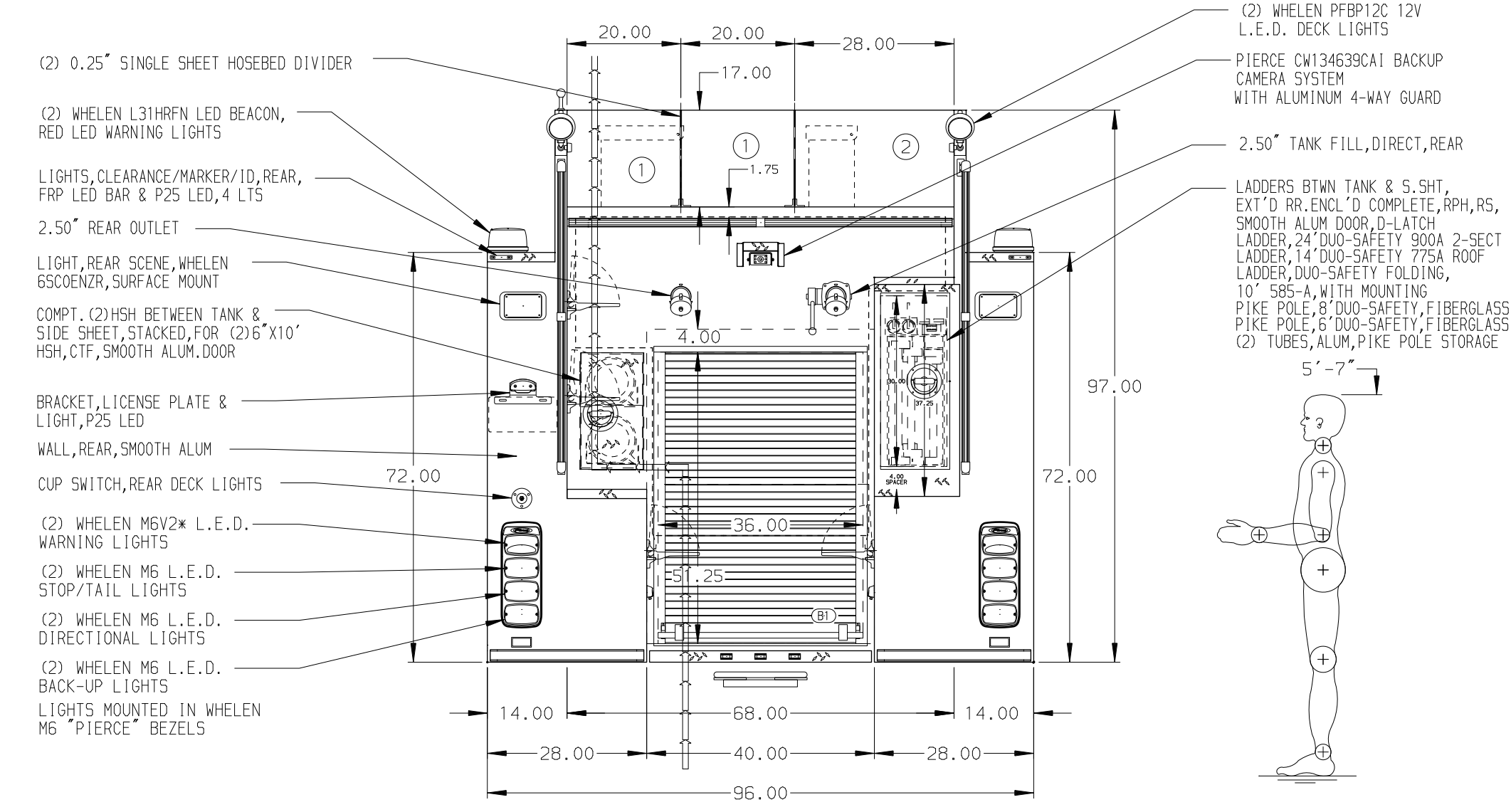
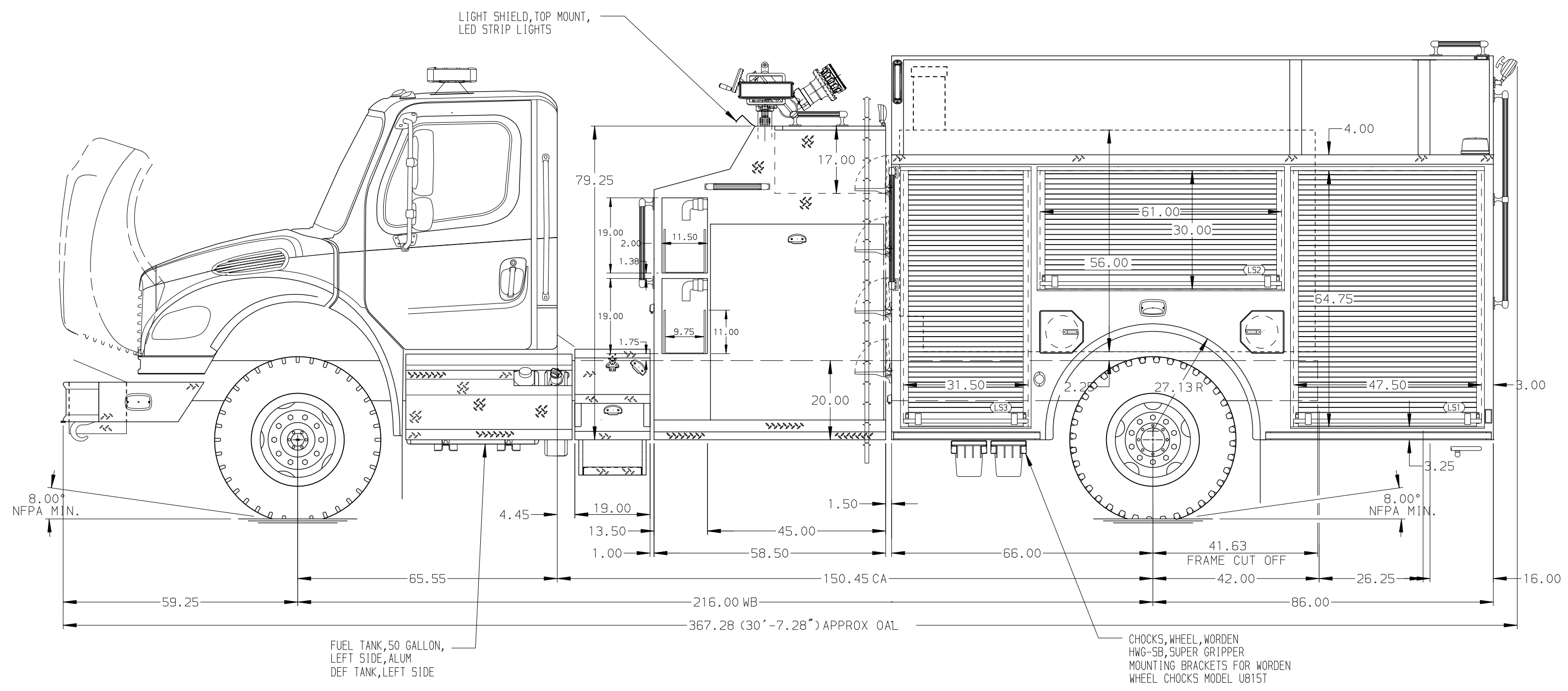

NOTE
DIMENSIONS SHOWN ARE APPROXIMATE AND ARE SUBJECT TO MINOR DEVIATIONS AS MAY OCCUR OR BE NECESSARY IN CONSTRUCTION. MINOR DETAILS NOT SHOWN.

				CHASSIS DATA	TITLE	1250-D-1000P, 20 FOAM, 152" BODY, LS&RS FL HIGHT FDLER 45' TOP MOUNT W/19" WALKWAY, (2) 1.5" SPDLAYS W/POLY TRYS	JOB NO.	34597	
				MAKE	FOR	GREEN TOWNSHIP FIRE DEPARTMENT LACHINE, MICHIGAN	SCALE	1:24	
				MODEL	DWG NO.	34597AD	DRAWN BY	JLA	
				REV	DATE	BY	CH	DATE	
16	JUN	20	RHU	DDR	FL			24FEB20	
07	MAY	20	CRH	DDR	M2-106			25FEB20	
								CHECKED BY	RWI
								SHEET SIZE	D
								SHEET NO.	1 OF 1